

Description:

Compact and complete 5000 m³/hr, 3 Line Priority Panel all in one unit. Sequential operation as opposed to the inferior parallel models. Infinite pressure control, monitoring, isolation and distribution for high pressure compressed natural gas installations. Suitable for use in all Sweet Natural Gas, inert and non-corrosive gas applications. Ready-made Priority Panels simplify station installation, fault diagnosis and maintenance. Eclipse mechanical Priority Panel is compatible with any kind of compressor package and dispenser brand.

Cartridge type valve configurations allow for easier access for servicing. No external connections between valves, reducing leakage concerns. Well-proven regulator and check valve designs ensure continual and accurate operation. Simple, on-site adjustment to set required pressures.

Performance:

Flow rate: 5000 m³/hr at 3200 psi (201 bar) SG 0.6
 MAWP: 5000 psi (345 bar)
 Set pressure: 2500 - 4500 psi

Port options available on all ports.

Standard Specifications:

- Nominal Bore: 20 mm
- Filtration requirement: 20 micron
- Temperature range: -40°C to 80°C
- 410 Bar pressure gauges
- Compressor Connection -12 SAE
- Storage Connections 3/4" Npt
- Dispenser Connections 3/4" Npt with Shuttle valves
- 3 way Ex II ATEX approved 10w 240/250V Solenoid with 2 Meter Fly Lead
- Optional 5000 psig Compressor Monitoring / Setting Gauge Assembly

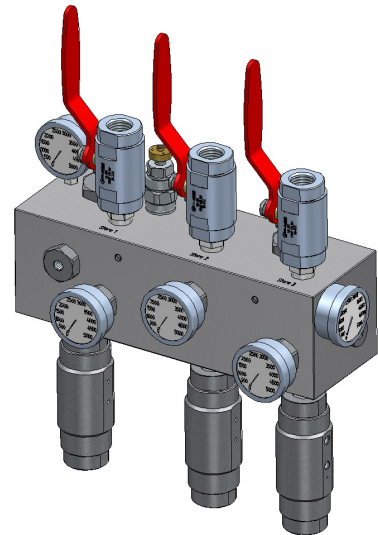

Materials:

- Manifold Aluminium Alloy
- Manifold seals Nitrile
- Manifold valve seats PTFE
- Actuator Body Aluminium Alloy
- Shuttle Stainless

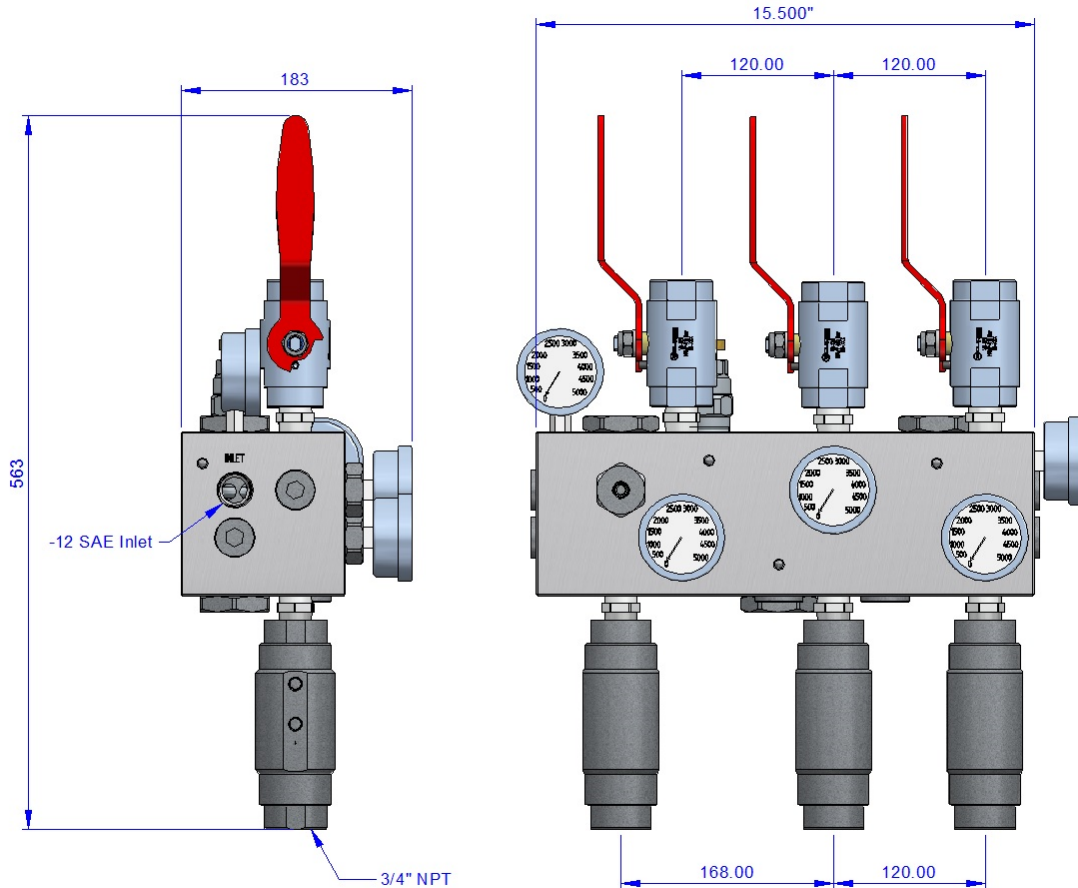

Operation:

Compressor flow is prioritized to the high pressure dispenser line and when the set pressure is reached the first pressure maintaining valve opens allowing filling of the first storage bank. When the first storage bank reaches set pressure the next valve opens and the second storage bank is filled. Likewise when that storage level is reached, the third storage bank is filled.

Due to using dome-loaded back-pressure valves, there is minimum pressure drop and droop. The entire setting is done by adjusting one pressure regulator integral with the system. Four non-return valves prevent back-flow.

We know of no competitors to this valve manifold. Its reliability and outstanding performance have been proven since its first commercial use in 1994.

Ordering Information:

Please supply the following information when ordering

- Outlet pressure range
- Port configuration
- Operating and storage temperature ranges

www.eclipsevalves.com

Email: sales@eclipsevalves.com

Phone: +64 9 292 9115

113 North Rd, Clevedon, Auckland 2582, New Zealand



