

Description:

Compact and complete single line back-pressure regulator/priority valve with infinite pressure control for high pressure CNG installations. The valve configuration allows for easier access for servicing. Well proven regulator designs ensure continual and accurate operation. Simple, on-site adjustment to set required pressures.

Designed to in accordance to NZS 5425, AG 504, NFPA 52

Performance:

Flow Rating:	8.4 Cv
Characteristics:	3-5% Drop from Shut to full open
Maximum Flow Rate:	4000 m ³ /hr at 15BarGdp @ 3200psi inlet
Maximum Inlet Pressure:	5000 psi (350 Bar)

Port configuration:

- Inlet:	1" NPT
- Outlet:	1" NPT
- Gauge:	1/4"

Standard Specifications:

- Nominal Bore:	3/4"
- Weight approx:	4.6 kg
- Filtration requirement:	20 micron
- Temperature range:	-40 to 85°C

Materials:

- Body:	304 Stainless Steel
- Valve components:	Stainless Steel
- Seals:	Nitrile
- Valve seat options:	PTFE, PCTFE, Nitrile, PEEK, EPDM, FKM

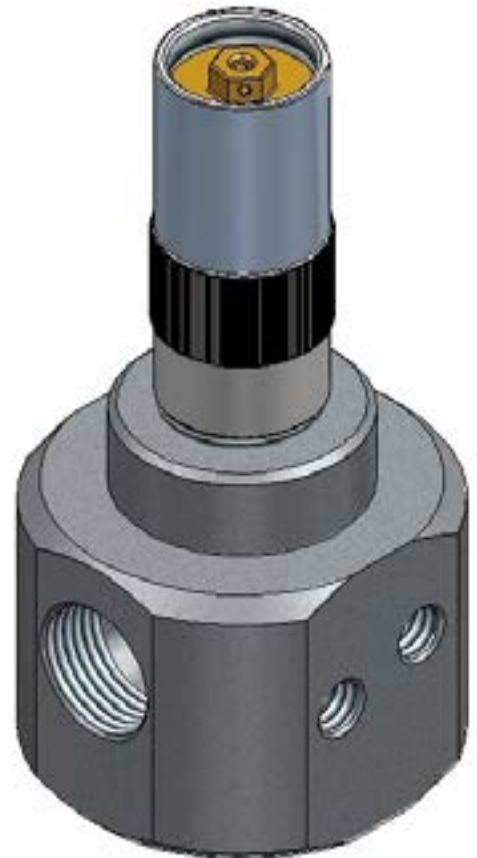

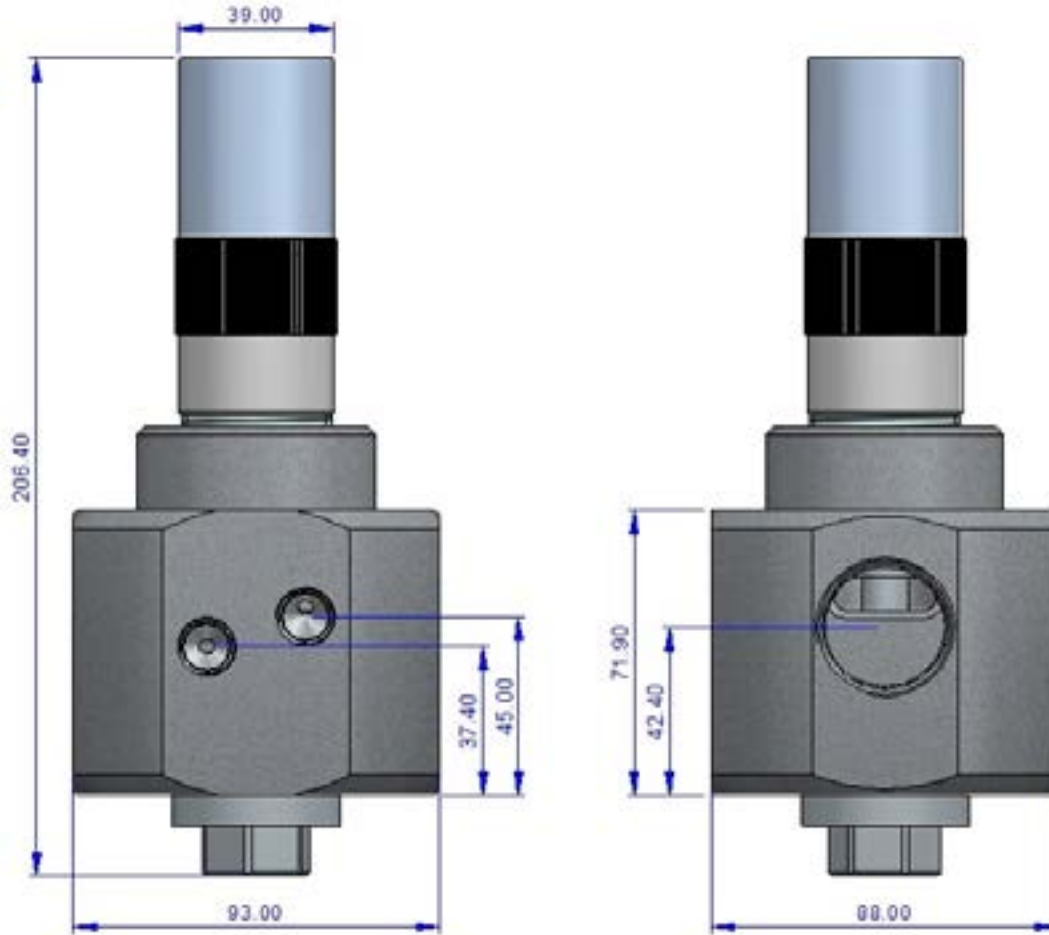

Ordering Information:

Please supply the following information when ordering:

- Outlet pressure range
- Flow medium
- Port configuration
- Operating and storage temperature ranges

If an option is required that is not listed, please contact our sales team.