

High performance Dome-Loaded Back-Pressure regulator for use with high pressure CNG systems. This specific design allows for a more stable regulated pressure range and is less susceptible to fluctuation. This configuration enables the trailer filling temperature to be lower than its competitors. Extra-large ports allow for extra flow and removable lower cap and shuttle mounted seat allow for ease of servicing.

Best suited for trailer-filling and other high-flow applications where back-pressure can aid in keeping filling temperatures lower, reducing trailer fill times.

Designed to in accordance to NZS 5425, AG 504, NFPA 52

Performance:

Flow Rating	Cv 10.5	
Maximum Inlet Pressure	5000 psi	(350 bar)

Port Configuration:

- Inlet	1" NPT
- Outlet	1" NPT

Standard Specifications:

- Nominal Bore	1.0 inch (25mm)
- Weight approx	5.7kg (no tubing or pilot)
- Filtration requirement	20 micron (not supplied)
- Temperature range	-40°C to 80°C

Materials:

- Body	Stainless Steel
- Valve components	Stainless Steel
- Seals	Nitrile Standard, others available.
- Valve seat options	PTFE standard, contact engineering for customised solutions.

Features:

- Balanced poppet design
- Dynamic regulation
- Heavy duty construction
- Trailer fill temperature reduced



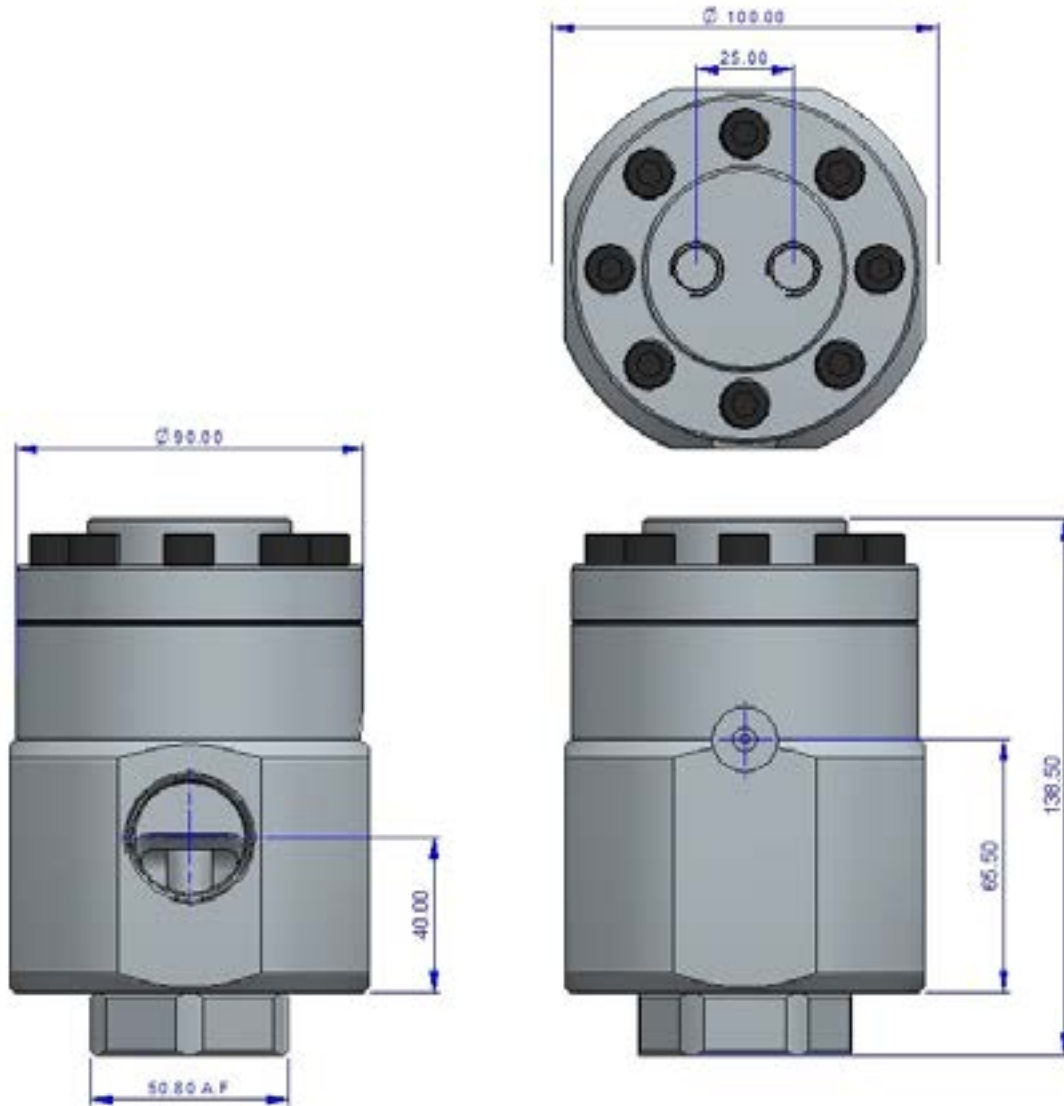

Ordering Information:

Please supply the following information when ordering:

- Outlet pressure range
- Flow medium
- Port configuration
- Operating and storage temperature ranges